

SPARKSHIELD (metric)

CYCLONE SPARK ARRESTER

The SparkShield provides highly effective removal of sparks and cigarette butts. Besides, it is a very effective in-line pre-separator reducing dust load in the connected filter system.

The SparkShield is to be mounted in horizontal position. Its divisible housing enables maintenance without duct disassembly.

The SparkShield comes with a dustbin of 13 and 27 litres. The distance between the spark arrester and dustbin can be enlarged by a duct of Ø 200 mm.



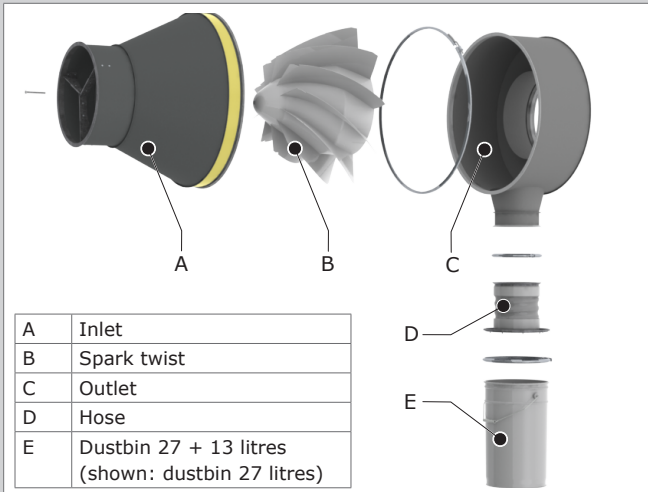
APPLICATIONS

The SparkShield is part of Plymovent's *SHIELD fire safety solutions* and recommended to be used in applications with a high fire risk, such as:



- robotic welding of oily stamped products
- robotic and automatic welding of oily products
- manual welding of oily products
- cutting tables
- schools and other areas with risk of cigarette butts

MAIN COMPONENTS



SPECIFICATIONS

Physical dimensions and properties

Material:	<ul style="list-style-type: none"> • inlet + outlet • spark twist • dustbin • hose 	<ul style="list-style-type: none"> • powder-coated steel • galvanized steel • tin • glassfibre/kevlar/metal
Colour:	<ul style="list-style-type: none"> • inlet • outlet • dustbin • hose 	<ul style="list-style-type: none"> • grey RAL 7011 • grey RAL 7035 • natural • grey/black

Product combinations

Refer to the application data sheet about Plymovent's SHIELD fire safety solutions for recommended product combinations.

Scope of supply

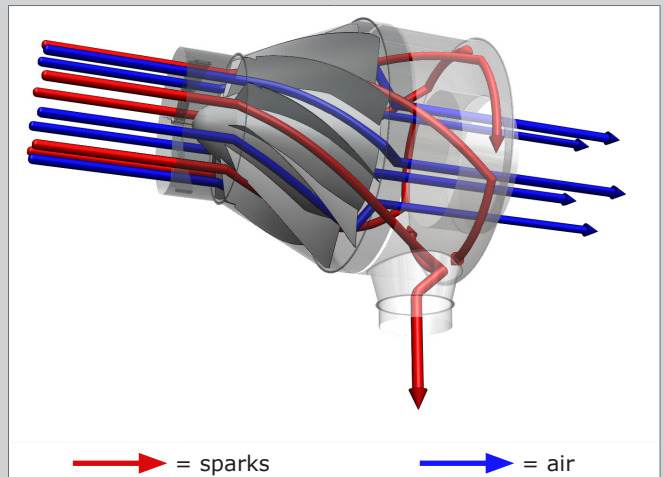
Spark arrester, consisting of inlet with SparkTwist and outlet, connected by duct clamp - Dustbin 13 litres + 27 litres - Dustbin cover incl. connection flange + hose - Duct connection material

For more detailed specifications: refer to Table 1

SHIPPING DATA

Harmonized Tariff Code	8421.39.2090
Country of origin	Netherlands

SEPARATION OF SPARKS

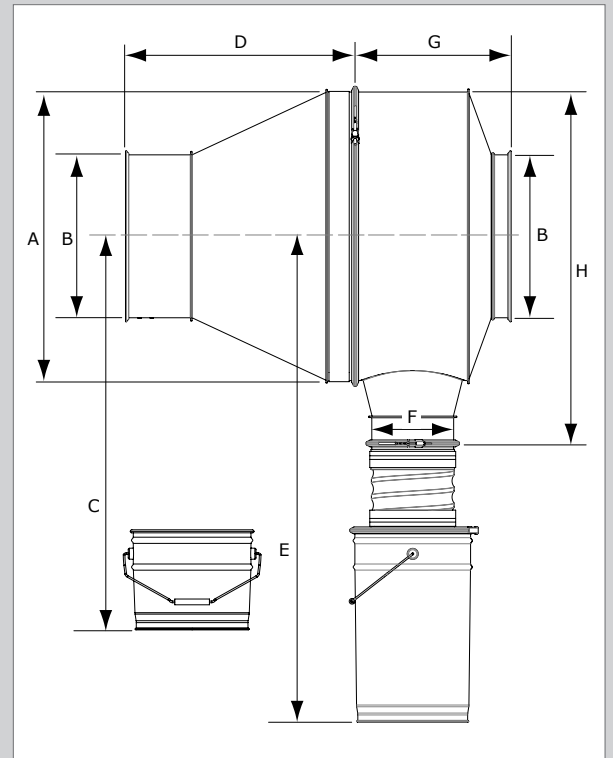


INSTALLATION POSSIBILITIES

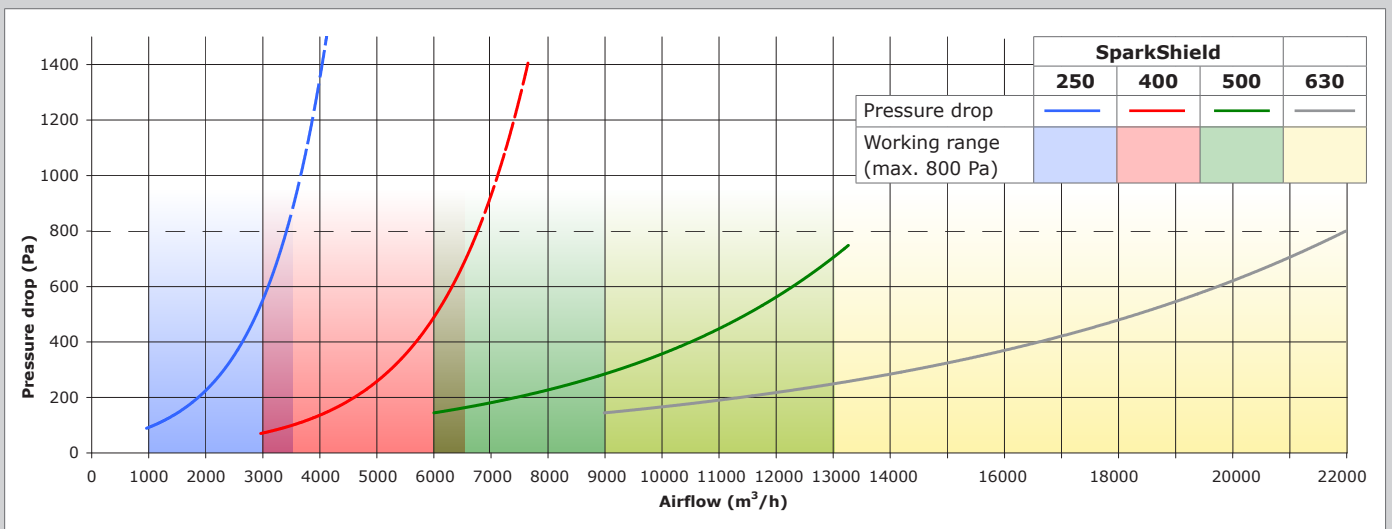


Table 1: specifications per type

	SparkShield			
	250	400	500	630
PHYSICAL DIMENSIONS AND PROPERTIES				
A	Ø 500 mm	Ø 710 mm	Ø 900 mm	Ø 1125 mm
B	Ø 250 mm	Ø 400 mm	Ø 500 mm	Ø 630 mm
C	min. 825 mm	min. 970 mm	min. 1095 mm	min. 1200 mm
D	433 mm	558 mm	654 mm	770 mm
E	min. 1050 mm	min. 1200 mm	min. 1325 mm	min. 1430 mm
F	Ø 200 mm	Ø 200 mm	Ø 200 mm	Ø 200 mm
G	345 mm	385 mm	505 mm	630 mm
H	616 mm	866 mm	1086 mm	1518 mm
Weight (net):				
• total	• 24 kg	• 36 kg	• 54 kg	
• spark arrester only	• 20 kg	• 32 kg	• 50 kg	
Appropriate duct size	Ø 250 mm	Ø 400 mm	Ø 500 mm	Ø 630 mm
OPTIONS AND ACCESSORIES				
Inspection hatch	IH-200/8 IH-250/10 (2x)	IH-200/8 IH-400-16 (2x)	IH-200/8 IH-500/20 (2x)	2 integrated inspection & service hatches
Manual damper	MD-200	MD-200	MD-200	
EFC	Industrial detergent			
ORDER INFORMATION				
Article number	9760001010	9760001020	9760001030	
SHIPPING DATA				
Gross weight excl. pallet	28 kg	41 kg	60 kg	
(incl. pallet)	(37 kg)	(54 kg)	(85 kg)	
Packing dimensions	80 x 60 x 80 cm	120 x 80 x 100 cm	120 x 100 x 120 cm	



PRESSURE DROP & WORKING RANGE



The installation of any product(s) not included in the initial design of an extraction system could add additional static pressure to the overall system design. By doing so, the result may be a reduction of airflow at the extraction point.

Product type **SparkShield (metric)**
 Article no. refer to order information
 Product category SHIELD fire safety solutions
 Version 080916/D

Always check the latest version on www.plymovent.com